

DIN 917

- Kör Somun
- Hexagon Cap Nuts
- Sechskant-Hutmuttern niedrige Form

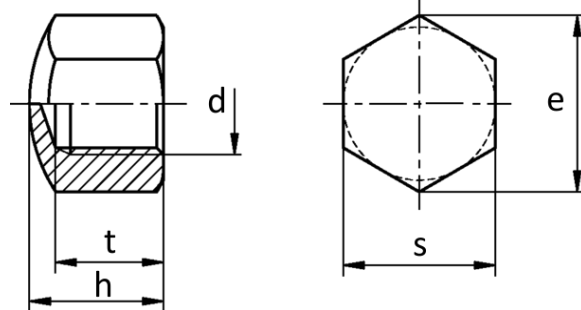

d	M 4	M 5	M 6	M 8 M 8x1	M 10 M 10x1 M 10x1,25	M 12 M 12x1,5 M 12x1,25	M 14 M 14x1,5
P (pitch)	0,7	0,8	1	1,25	1,5	1,75	2
h	5,5	7	9	12	14	16	18
t (max)	4,64	5,44	7,29	9,79	11,35	13,85	15,35
s	7	8	10	13	16	18	21
e (min)	7,66	8,79	110,5	14,38	17,77	20,03	23,35

d	M 16 M 16x1,5	M 18 M 18x1,5 M 18x2	M 20 M 20x2 M 20x1,5	M 22 M 22x1,5 M 22x2	M 24 M 24x2	M 27 M 27x2	M 30 M 30x2
P (pitch)	2	2,5	2,5	2,5	3	3	3,5
h	20	22	25	28	30	32	34
t (max)	17,35	19,42	21,42	22,42	24,42	26,42	28,42
s	24	27	30	32	36	41	46
e (min)	26,75	29,56	32,95	35,03	39,55	45,20	50,85

d	M 36 M 36x3	M 42 M 42x3	M 48 M 48x3	M 56 M 56x4	M 64 M 64x4	M 72x6 M 72x4
P (pitch)	4	4,5	5	5,5	6	–
h	44	52	58	68	75	85
t (max)	36,5	42,5	48,5	56,6	62,6	67,6
s	55	65	75	85	95	105
e (min)	60,79	72,02	82,60	93,56	104,86	116,16

